

## SWING CHECK VALVE FLANGED END JIS 10K

Model: ARV-SWJ74820

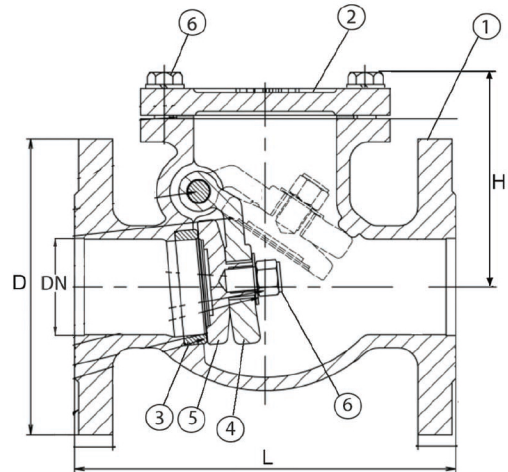

### Technical Data

#### Features :

Face to face is according to JIS B2002  
 Flange drilled is according to JIS B2212  
 Working Pressure : 16 kgf/ cm<sup>2</sup>  
 Test Pressure Shell : 21.1 kgf/cm<sup>2</sup>  
 Seat : 15.0 kgf/cm<sup>2</sup>  
 Working Temperature : -10 to 120°C

#### Material

No	PART	MATERIAL
1	BODY	CAST IRON
2	BONNET	CAST IRON
3	DISC	CAST IRON
4	SEAT RING	CAST BRONZE / STAINLESS STEEL
5	INGE PEN	STAINLESS STEEL
6	DRAIN PLUG	CARBON STEEL

#### Dimension in mm

SIZES	1.1/2"	2"	2.1/2"	3"	4"	5"	6"	8"	10"	12"
DN	40	50	65	80	100	125	150	200	250	300
L	190	203	220	240	292	330	356	495	622	698
H	100	105	115	140	155	170	203	246	283	330
D	140	155	175	185	210	250	280	330	400	445